

Watch Movement Specification and Drawing

CALENDAR

**Cal. VX82E**

Movement Size

**6 3/4 × 8'''**

Casing Diameter

**15.3 × 17.4 mm**

Height

**2.75mm**

Battery Life

**3 years**



Date: 18/Sep./'20

# Cal. VX82E

Items	Rev.	Page
Specifications	04	1
Appearance	02	2
Casing	03	3
Hand fitting	03	4
Hand setting stem	02	5
Dial-01	01	6-01
Dial-02	01	6-02
Casing ring	01	7

**Analog Quartz 6 3/4 × 8''' Slim Movement / Three Hands (H/M/S) with Calendar****1. MOVEMENT DIMENSIONS**

Outside diameter	15.70mm(3-9H) × 17.80mm(12-6H)
Casing diameter	15.30mm(3-9H) × 17.40mm(12-6H)
Total height	2.75mm (including battery)

**2. TIME STANDARD**

Type of quartz oscillator	Tuning fork
Frequency of quartz oscillator	32,768 Hz
Accuracy	±20 seconds per month (on wrist)
Operating temperature range	-5°C to +50°C
Regulation device	Nil (Pre-adjusted)

**3. INDICATOR / FUNCTIONS**

3 Hands	Hour / Minute / Second
Calendar	Instant setting device for date calendar
Reset switch	
Setting mechanism	Crown at normal position : Free Crown pulled out 1st click : Instant date change Crown pulled out 2nd click : Time setting / Reset

**4. FEATURES**

Jewels	0 Jewels
Anti-magnetism	Over 1600A/m (Direct current magnetic field)
Maximum unbalance of hands	Hour hand : 0.5 μ N·m Minute hand : 0.6 μ N·m Second hand : 0.07 μ N·m

**5. BATTERY**

Type / Size	Silver oxide battery / φ 6.8mm × t 2.1mm
Recommended battery	SR621SW (Maxell, Murata, Seizaiken)
Nominal voltage	1.55 V
Battery life	Approx. 3 years
Driving current consumption	Approx. 0.80 μ A
Operation stopping voltage	0.9 V

**6. SEPARATED PARTS (Parts code)**

Hand setting stem	0351177 or 0351578
Battery	SR621SW

**7. TEST OF ACCURACY**

Equipment to be used	SEIKO quartz tester QT-99, Greiner quartz timer-C , Witschi Q-tester 4000
Duration of measurement	10 seconds
Microphone to be used	Electromagnetic detection type

All specifications are subject to change without notice.

Hands type

	Mark
Type S (1) VX82E1**	1
Type M (2) VX82E2**	2

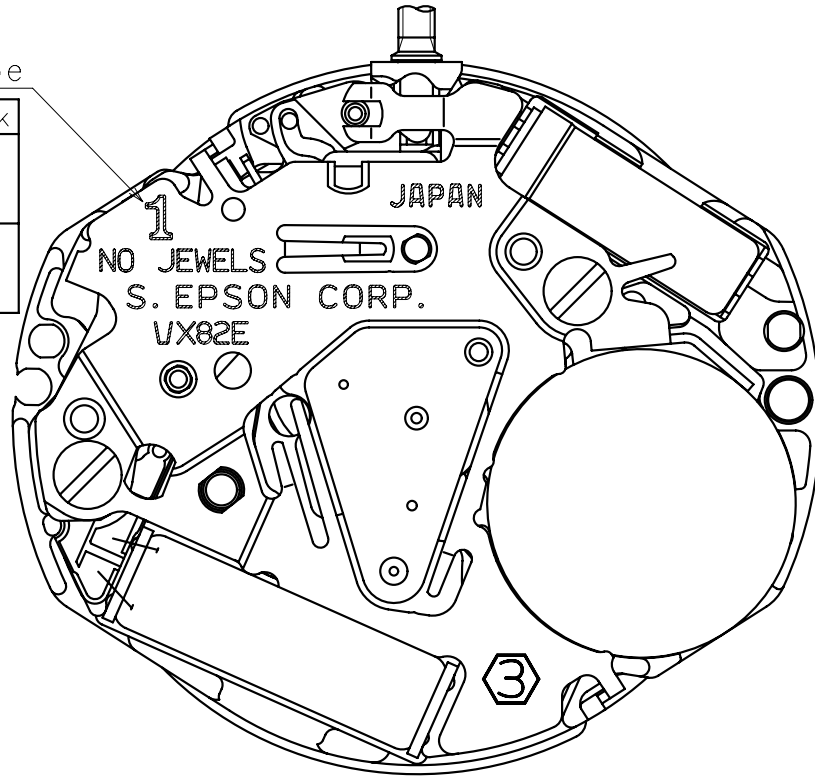

Dial leg hole B

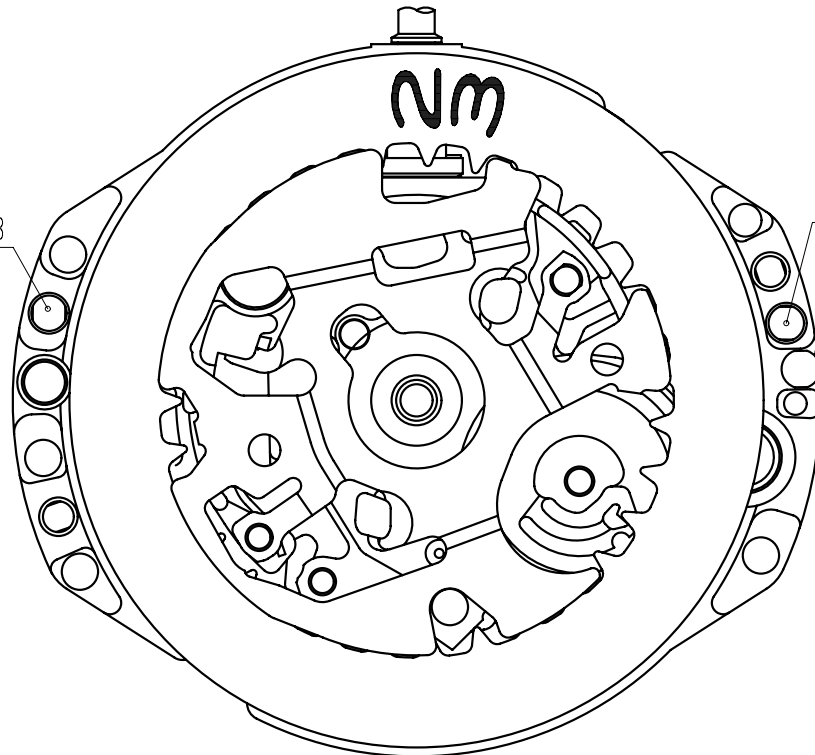

Dial leg hole A

※1:First pullout stroke

※2:Second pullout stroke

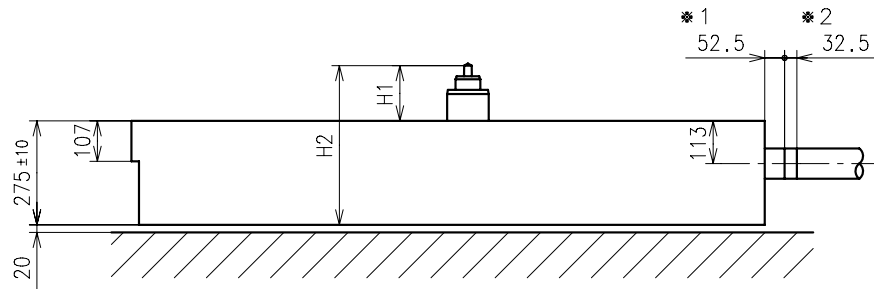

Center post		Type S (1) VX82E1**	Type M (2) VX82E2**
Maximum height from dial support	H1	140	182
Total height including movement	H2	415	457

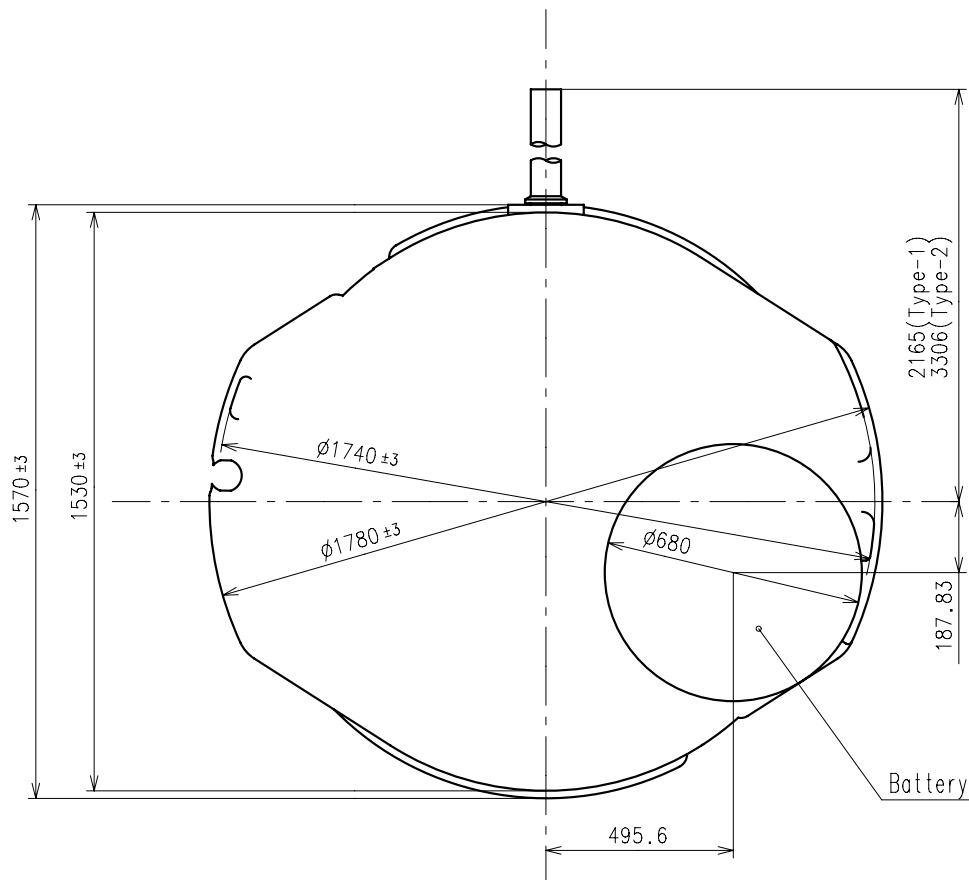

- \* Hour hand unbalance  $\leq 0.5\mu\text{ N}\cdot\text{m}$  ( $50\mu\text{ g}\cdot\text{m}$ )
- \* Minute hand unbalance  $\leq 0.6\mu\text{ N}\cdot\text{m}$  ( $60\mu\text{ g}\cdot\text{m}$ )
- \* Second hand unbalance  $\leq 0.07\mu\text{ N}\cdot\text{m}$  ( $7\mu\text{ g}\cdot\text{m}$ )

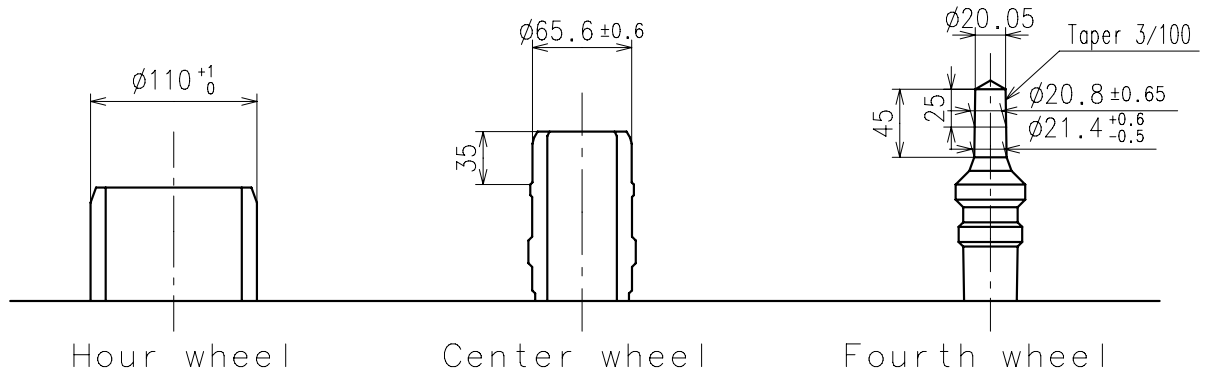

	Parts No.		
	Hour wheel	Center wheel	Fourth wheel
Type S (1) VX82E1**	0271929	0221929	0241929
Type M (2) VX82E2**	0271942	0221904	0241904

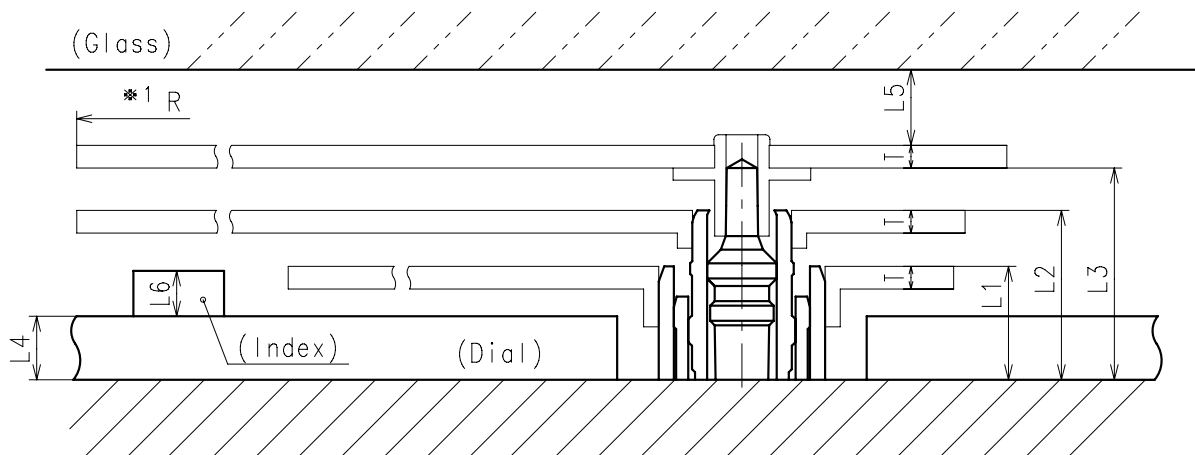

	L1	L2	L3	L4	L5	L6	T	*1 R
Type S (1) VX82E1**	75	112	140	40	MIN: 50	MAX: 30	15	MAX: 1250
Type M (2) VX82E2**	105	154	182	40	MIN: 50	MAX: 60	15	MAX: 1250

\*1: It is the size taken into consideration for hands attachment.  
Please observe some standard value specified in unbalance when using long hands.

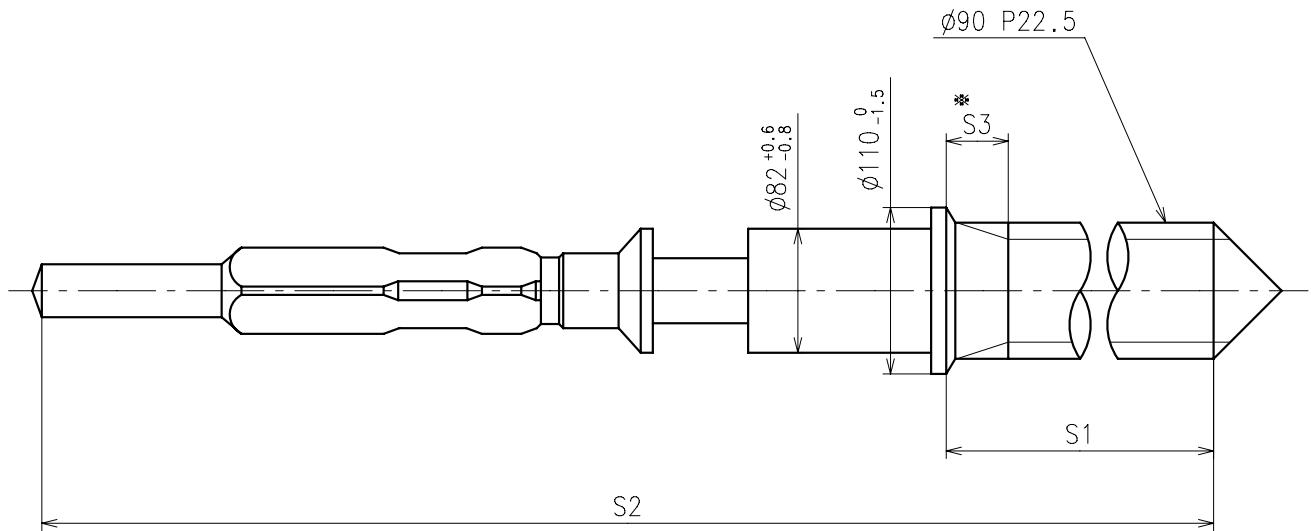

※ Not threaded

	Part No.	S1	S2	※ S3
Type-1 (Standard)	0351177	1366	1964	60
Type-2	0351578	2507	3105	650

Material : Steel

Hardness : Vickers 600±50

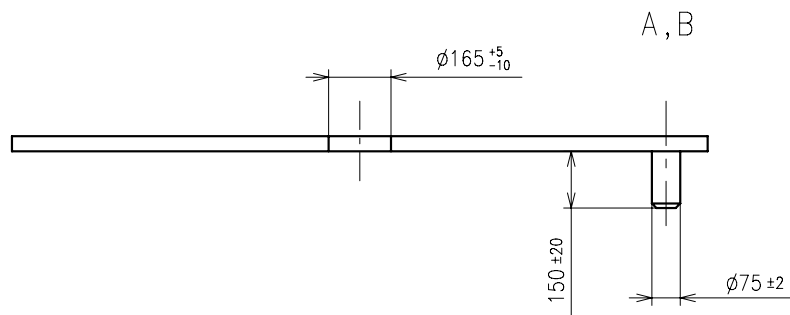
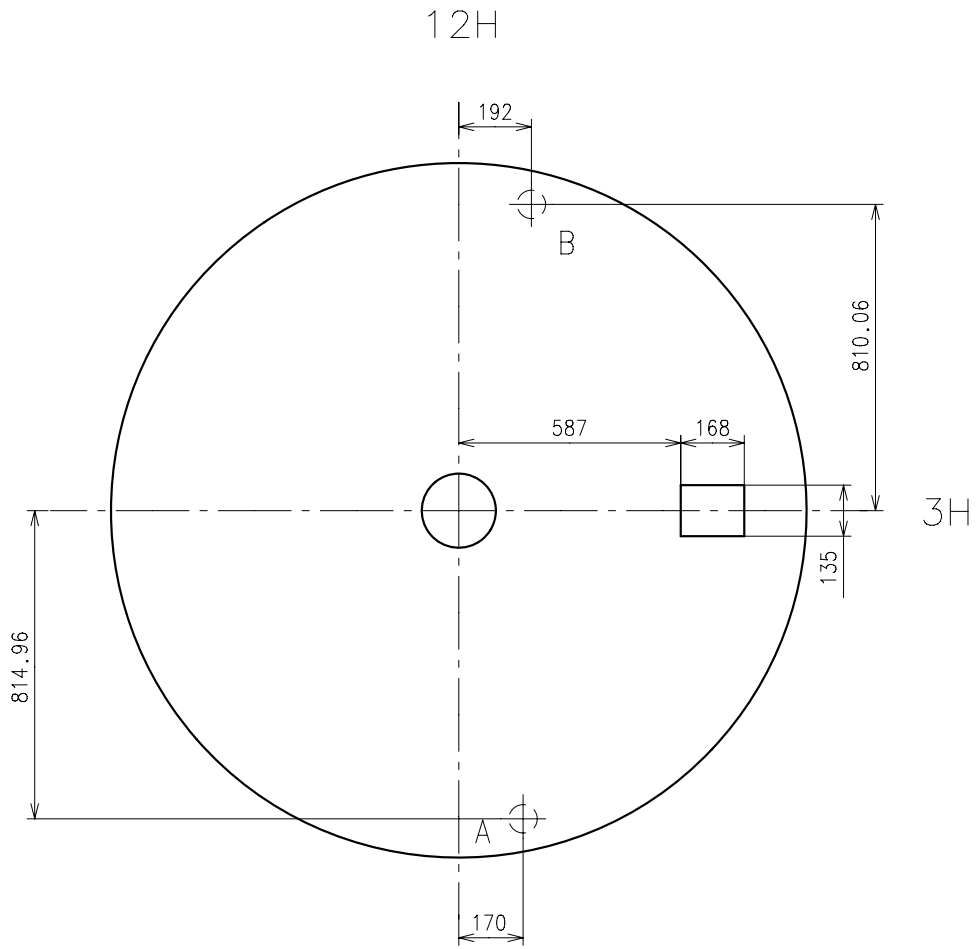



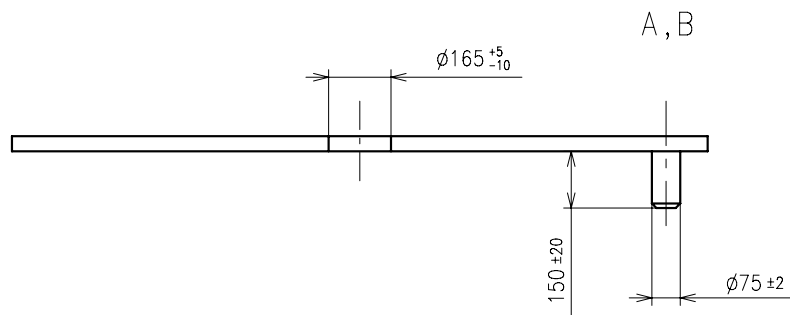
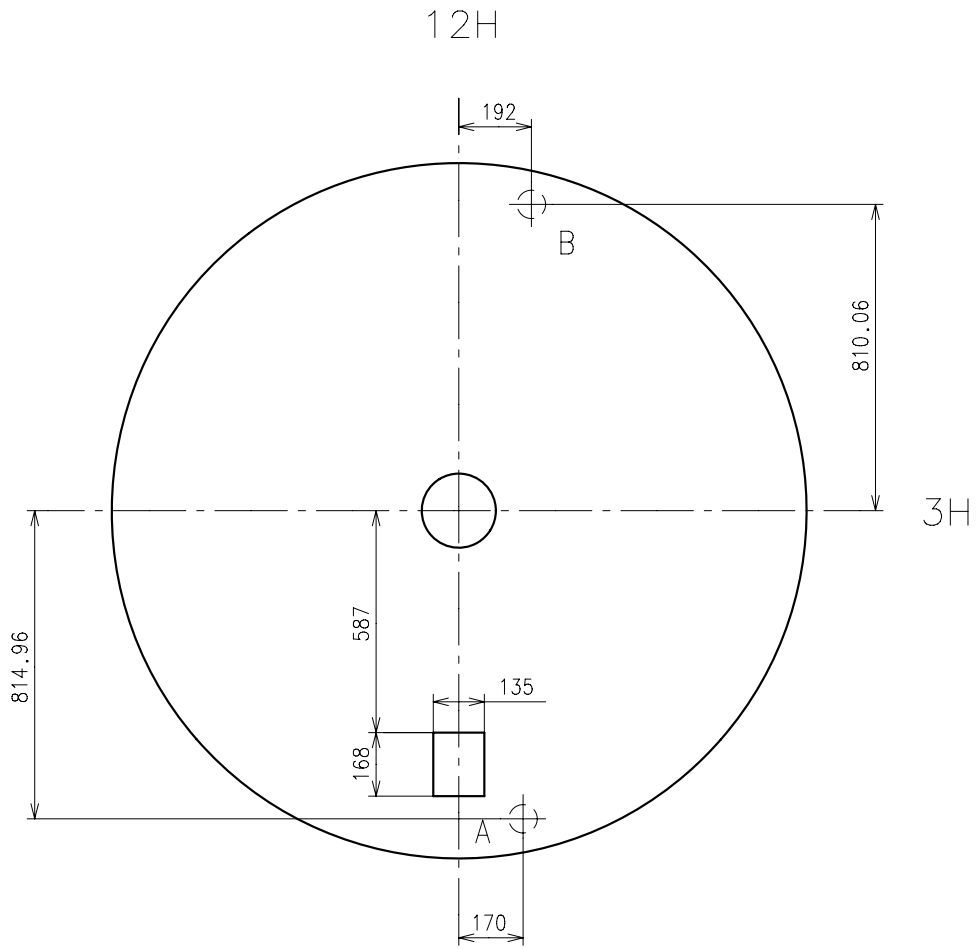

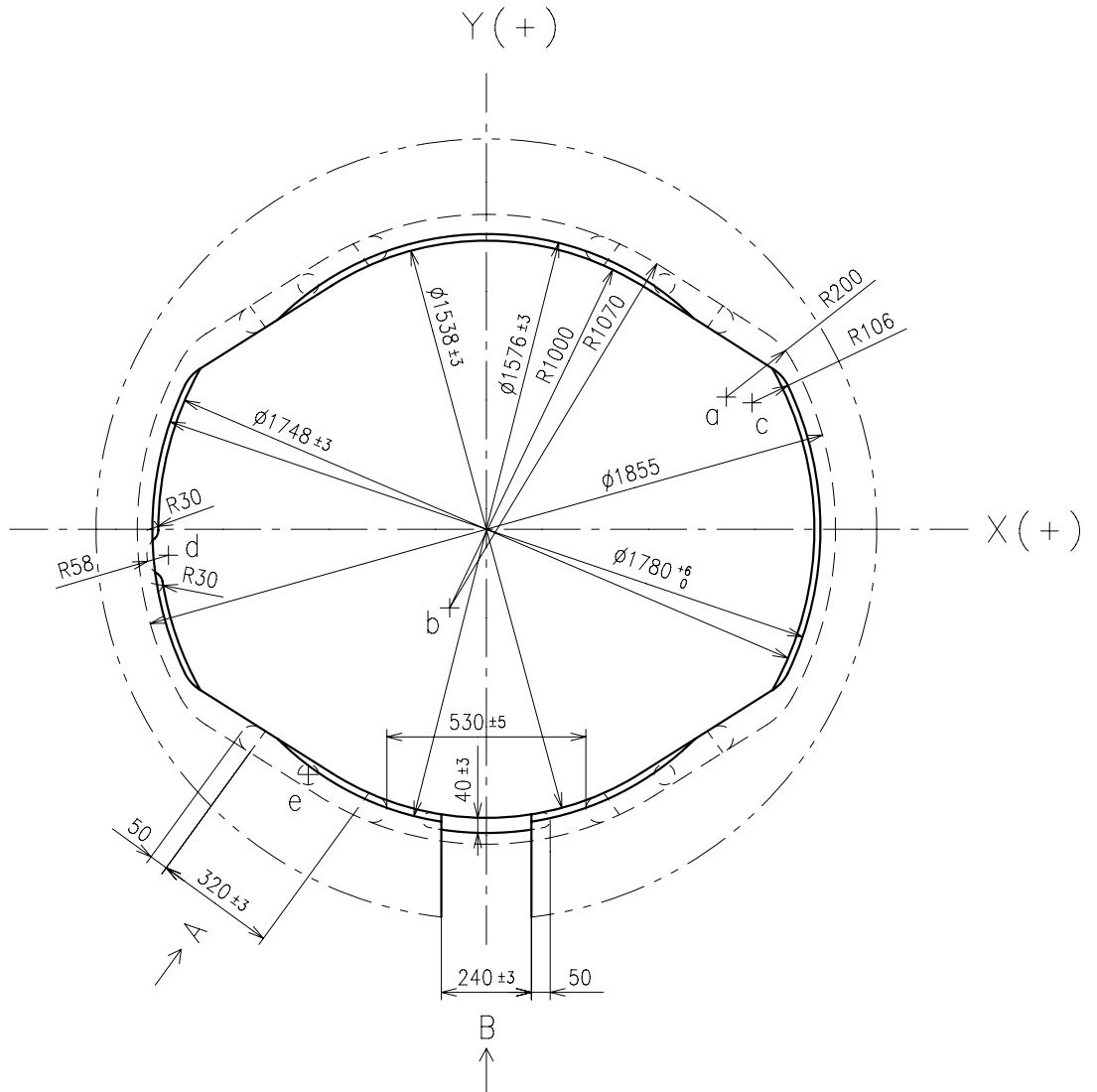

A view

B view

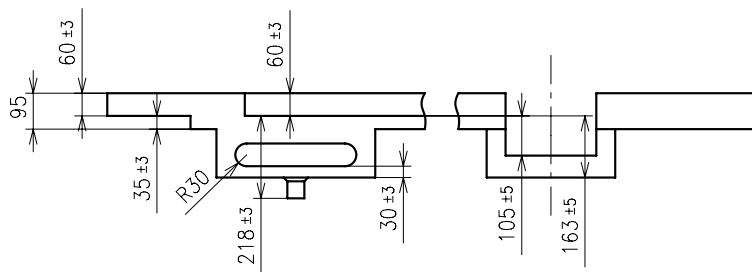

	X	Y
a	+639.35	+352.33
b	- 97.66	-209.34
c	+707.84	+337.08
d	-847.00	- 69.00
e	-474.61	-653.25